

OK2D872 Motor driver manual

Features :

- 1 Using DSP high-speed processor, the system completely solves the shortcomings of traditional stepper motors such as low-speed crawling, resonance zones, high noise, low high-speed torque, low starting frequency and poor driver reliability.
2. In low subdivision state, high-precision positioning can be achieved
3. Using the latest PI current control algorithm, the output torque is large, giving you unusual high-speed performance
4. It can adapt to harsh environments and has strong anti-interference ability;
5. The driver integrates parameter self-tuning function, which can generate different adaptation parameters for different motors, so that the motor can exert its excellent performance.

Weak current wiring signal description

Signal	Function
PUL+ (+5V)	Pulse signal: Pulse control signal, the rising edge of the pulse is valid at this time; PUL - 4-5V when high level, 0-0.5V when low level. For reliable response, the pulse width is greater than 1μS. This drive signal port is compatible with 5-24V and does not require a current limiting resistor.
PUL- (PUL)	
DIR+ (+5V)	Direction signal: high/low level signal, to ensure reliable response of the motor, corresponding to the forward and reverse directions of the motor. The direction signal should be established at least 5μs before the pulse signal. The initial running direction of the motor is related to the wiring of the motor. Swapping any phase winding (such as A+, A- swap) can change the initial running direction of the motor. When DIR- is high level, 4 -5V, 0-0.5V at low level. This drive signal port is compatible with 5-24V.
DIR- (DIR)	
ENA+ (+5V)	Enable signal: This input signal is used to enable/disable, high level enables, and the driver cannot work when low level. Under normal circumstances, it must be left unconnected and left floating to enable it automatically. This drive signal port is compatible with 5-24V and does not require a current limiting resistor.
ENA- (ENA)	

Description of strong power interface

Interface	Function
AC	AC power supply voltage (AC18-50V, if using DC voltage power supply, you can input DC24-80v, don't need to separate the positive and negative poles)
AC	AC power supply voltage (AC18-50V, if using DC voltage power supply, you can input DC24-80v, no need to separate the positive and negative poles)
A+, A-	Motor phase A. A+ and A- intermodulate, which can change the motor running direction once.
B+, B-	Motor phase B. B+ and B- intermodulate, which can change the motor's running direction once.

Output Current Configuration

Peak Current	SW1	SW2	SW3
2.40A	ON	ON	ON
3.08A	OFF	ON	ON
3.77A	ON	OFF	ON
4.45A	OFF	OFF	ON
5.14A	ON	ON	OFF
5.83A	OFF	ON	OFF
6.52A	ON	OFF	OFF
7.20A	OFF	OFF	OFF

OK2D872 Micro Step Configuration

Micro step	Pulses/Rev. (for 1.8°motor)	SW5	SW6	SW7	SW8
2	400	ON	ON	ON	ON
4	800	OFF	ON	ON	ON
8	1600	ON	OFF	ON	ON
16	3200	OFF	OFF	ON	ON
32	6400	ON	ON	OFF	ON
64	12800	OFF	ON	OFF	ON
128	25600	ON	OFF	OFF	ON
256	51200	OFF	OFF	OFF	ON
5	1000	ON	ON	ON	OFF
10	2000	OFF	ON	ON	OFF
20	4000	ON	OFF	ON	OFF
25	5000	OFF	OFF	ON	OFF
40	8000	ON	ON	OFF	OFF
50	10000	OFF	ON	OFF	OFF
100	20000	ON	OFF	OFF	OFF
200	25000	OFF	OFF	OFF	OFF

Full flow/half flow setting SW4:ON=full flow SW4:OFF=half flow (when stopping the pulse train, the current is half of the set value, reducing the heat generated by the drive and motor)

◆ Matching of driver and motor

This driver can drive two-phase and four-phase motors from various manufacturers at home and abroad. In order to obtain the most satisfactory driving effect, it is necessary to select a reasonable power supply voltage and set current. The level of the supply voltage determines the high-speed performance of the motor, and the current setting value determines the output torque of the motor.

● Selection of supply voltage:

Generally speaking, the higher the supply voltage, the greater the torque of the motor at high speed, and the better it can avoid Steps will drop at high speeds, but on the other hand, too high a voltage will cause overvoltage protection and may even damage the driver, and when working at high voltages, low-speed motion will cause greater vibration. Working at 150 rpm, 24V power supply is recommended

● Output current setting value:

For the same motor, when the current setting value is larger, the motor output torque is larger, but when the current is large, the heating of the motor and driver is also serious. Therefore, the general situation is to set the current to a value when the power supply is warm but not overheated during long-term operation.

1. Four-wire motor and six-wire motor high speed mode: The output current is set to be equal to or slightly less than the rated current of the motor.
2. Six-wire motor high torque mode: the output current is set to 70% of the motor's rated current;
3. Eight-wire motor series connection method: The output current is set to 70% of the rated current of the motor;

4.Eight-wire motor parallel connection method: the output current can be set to 1.4 times the rated current of the motor.

Note: Please run the motor for 15-30 minutes after setting the current. If the temperature of the motor rises too high, the current setting value should be reduced. If the motor output torque is not enough after reducing the current value, please improve the heat dissipation conditions to ensure that the motor and driver are not hot to the touch.

Motor wiring definition Red A+ Blue A- Green B+ Black B-

Install Picture:(unit: mm [1inch=25.4mm])

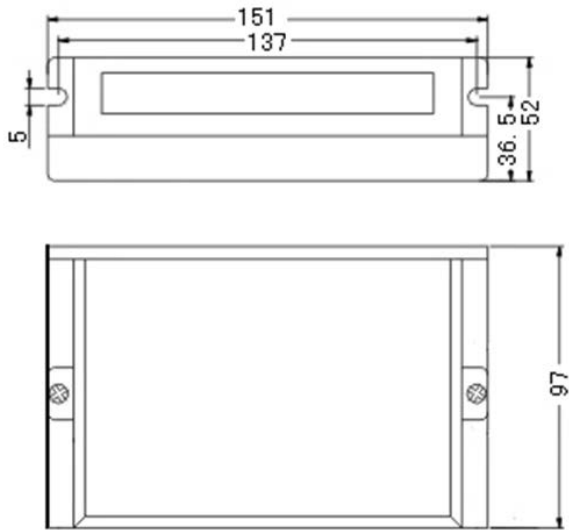

Product introduction:

NEMA 23 24 34 Dual phase motor driver
Low noise

Cooling fan

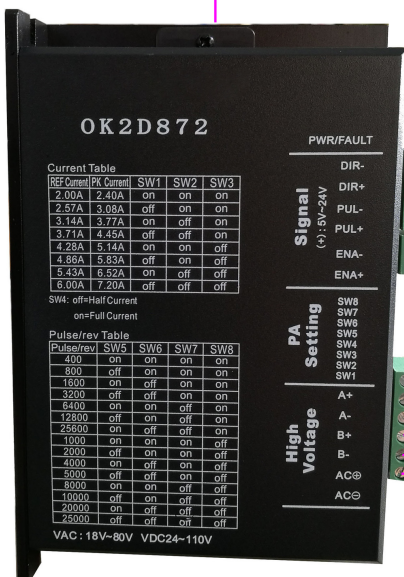

5-24v signal compatibility
 DIR- direction -
 DIR+ direction +
 PUL- pulse -
 PUL+ pulse +
 ENA- Enable -
 ENA+ Enable +
 SW5-SW8 Subdivision
 SW4 Full flow / half flow
 SW1-SW3 Current regulating
 Motor line A+
 Motor line A-
 Motor line B+
 Motor line B-
 Power Supply +
 Power Supply -
 AC18-80V DC24-110V
 AC and DC general purpose

32 bit DSP digital step motor driver

