

User Manual
For
Worm Gear Speed Reducer



Product summary

- Made of Aluminum alloy die-casting box, good looking in appearance, compact in structure rust proofing on Surface and small volume to save mounting space.
- Good radiating characteristic leads safe and high efficiency for using.
- The strong capacity of loading and overload ensure stable transmission, make less vibration and noise.
- Varies of connecting structure for power input and torque output meet different requirements; the design of box outline and the set of foot hole is apt to with many kinds of mounting.
- Besides big cases, no gap structure of box means a maintenance- free that is hermetically sealed. It prevents the lubricant from easily losing and going bad, and exchanging.

Products Structure View

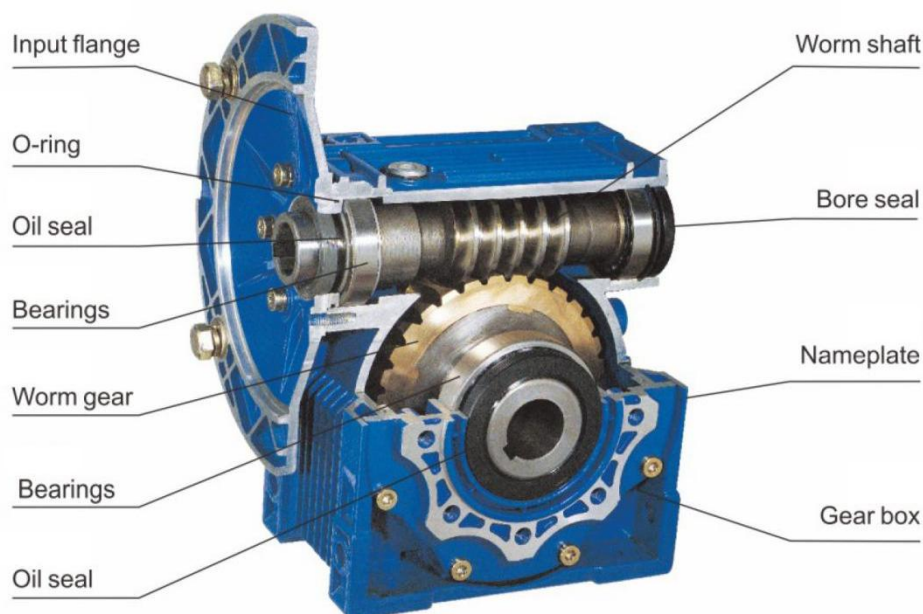

| Model | Gear Ratio | | | | | | | | | | |
|---------------|--------------------------------------|-------------------|-------------------|-------------------|-------------------|-------------------|-------------------|-------------------|-------------------|-------------------|-------------------|
| | 5 | 7.5 | 10 | 15 | 20 | 25 | 30 | 40 | 50 | 60 | 80 |
| NMRV30 | Moment Permissible Torque(Nm)[lb-in] | | | | | | | | | | |
| | 18.00 [159.31] | 18.00 [159.31] | 18.00 [159.31] | 18.00 [159.31] | 18.00 [159.31] | 20.00 [177.01] | 20.00 [177.01] | 17.00 [150.46] | 17.00 [150.46] | 17.00 [150.46] | 12.00 [106.21] |
| | Efficiency | | | | | | | | | | |
| | 87% | 85% | 82% | 76% | 73% | 67% | 65% | 58% | 55% | 52% | 43% |
| | Shaft Maximum Radial Load(kN) | | | | | | | | | | |
| | 0.57 | 0.68 | 0.75 | 0.86 | 0.94 | 1.02 | 1.08 | 1.19 | 1.28 | 1.36 | 1.50 |
| | Backlash@No-Load(°) | | | | | | | | | | |
| 1 | | | | | | | | | | | |

Dimension

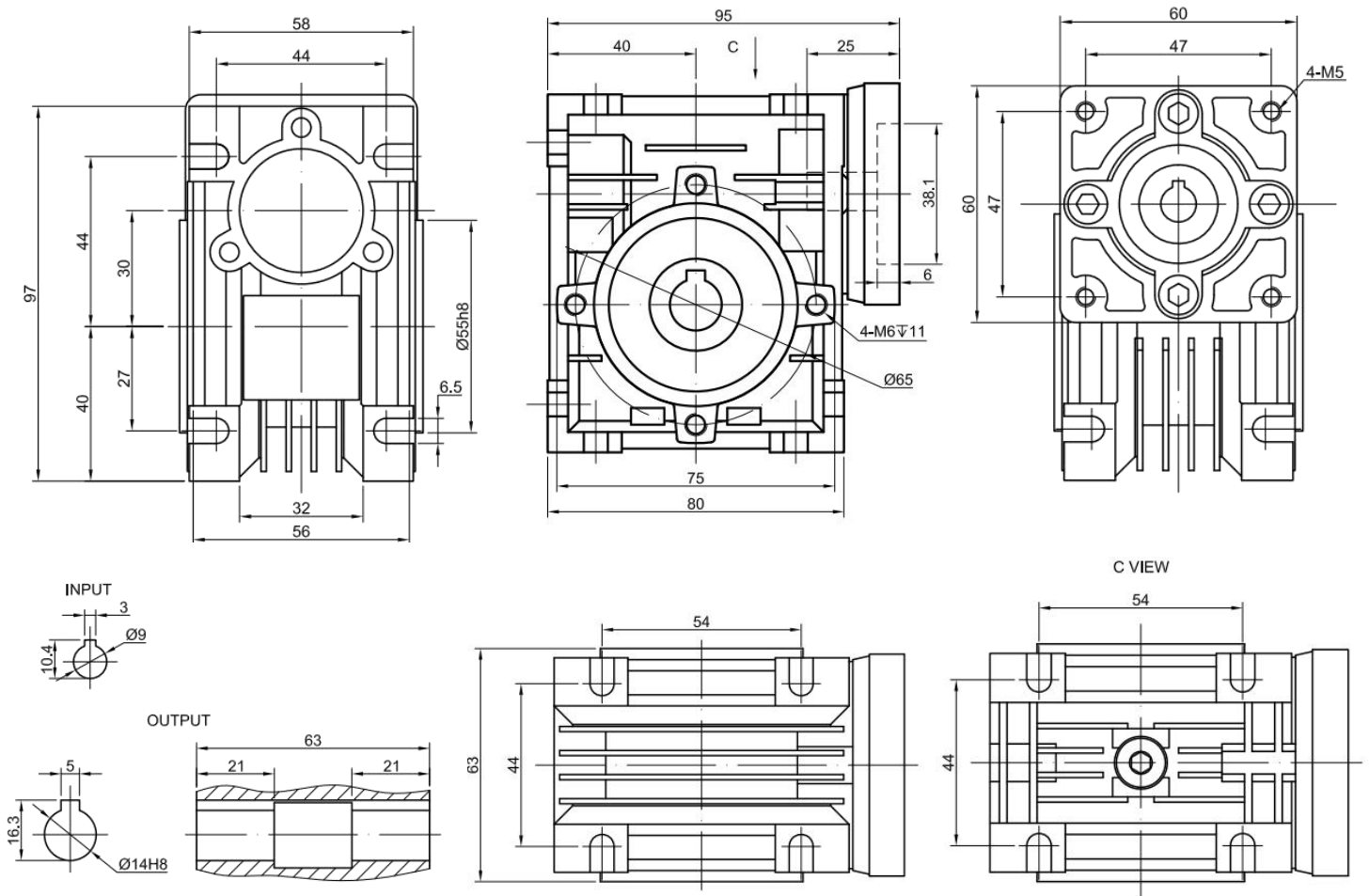

Output Shaft

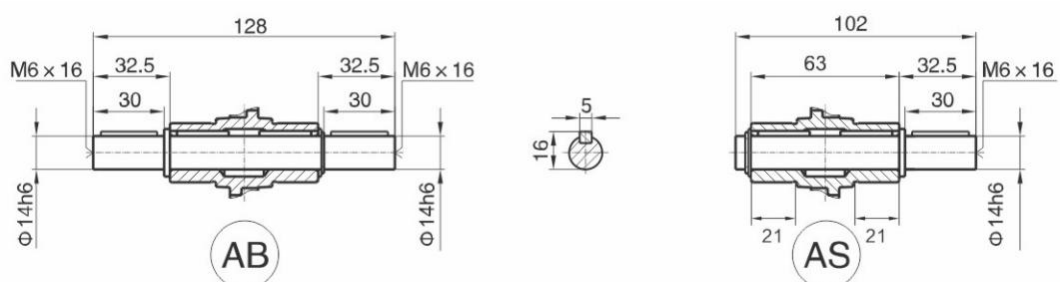

| Model | Gear Ratio | | | | | | | | |
|---------------|--------------------------------------|-------------------|-------------------|-------------------|-------------------|-------------------|-------------------|-------------------|-------------------|
| | 5 | 7.5 | 10 | 15 | 20 | 25 | 30 | 40 | 50 |
| NMRV40 | Moment Permissible Torque(Nm)[lb-in] | | | | | | | | |
| | 40.00 [354.03] | 40.00 [354.03] | 40.00 [354.03] | 40.00 [354.03] | 40.00 [354.03] | 40.00 [354.03] | 45.00 [398.28] | 40.00 [354.03] | 38.00 [336.33] |
| | Efficiency | | | | | | | | |
| | 87% | 85% | 83% | 82% | 78% | 75% | 70% | 65% | 62% |
| | Shaft Maximum Radial Load(kN) | | | | | | | | |
| | 1.18 | 1.31 | 1.44 | 1.65 | 1.82 | 1.96 | 2.08 | 2.29 | 2.47 |
| | Backlash@No-Load(°) | | | | | | | | |
| 1 | | | | | | | | | |

Dimension

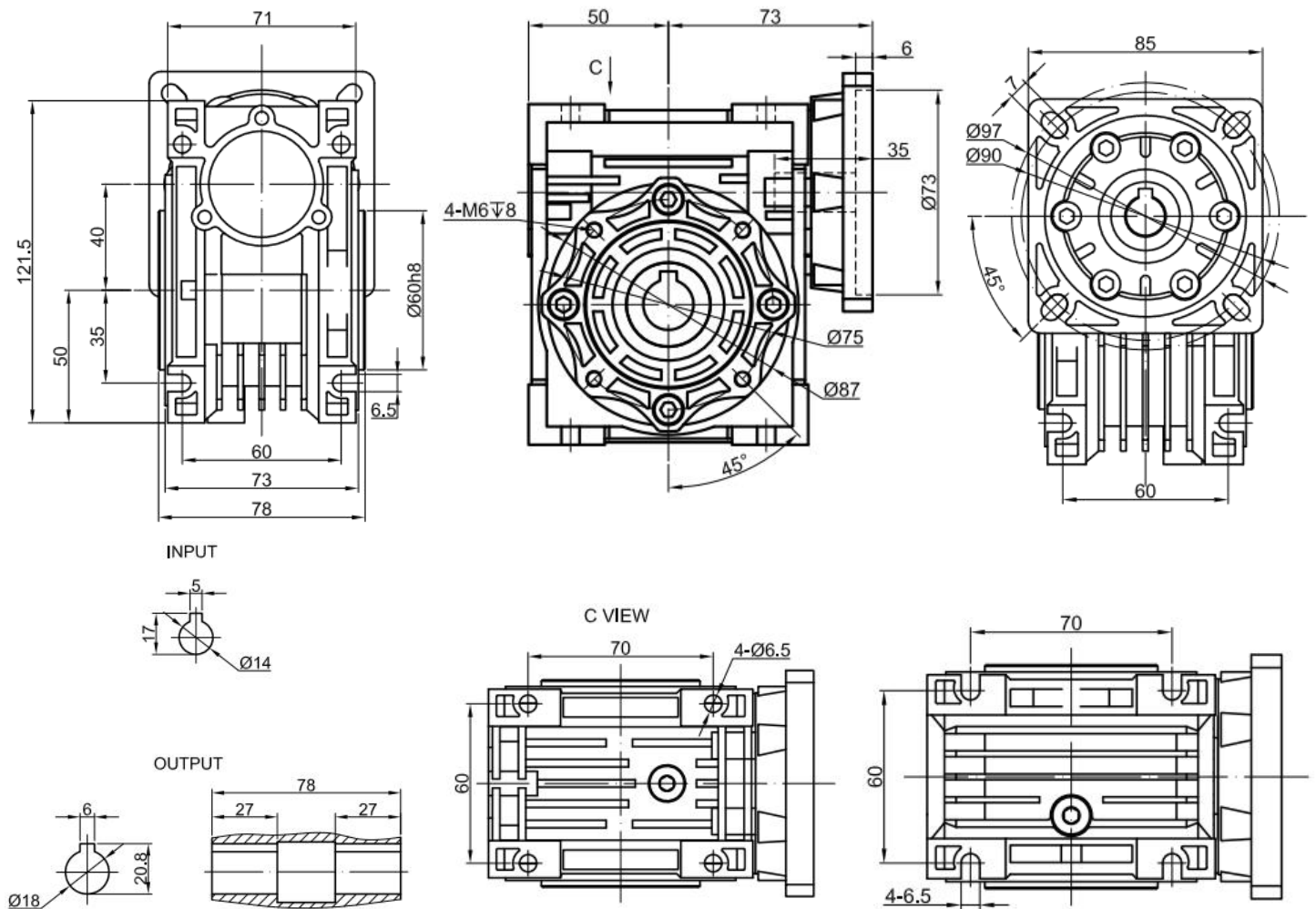

Output Shaft

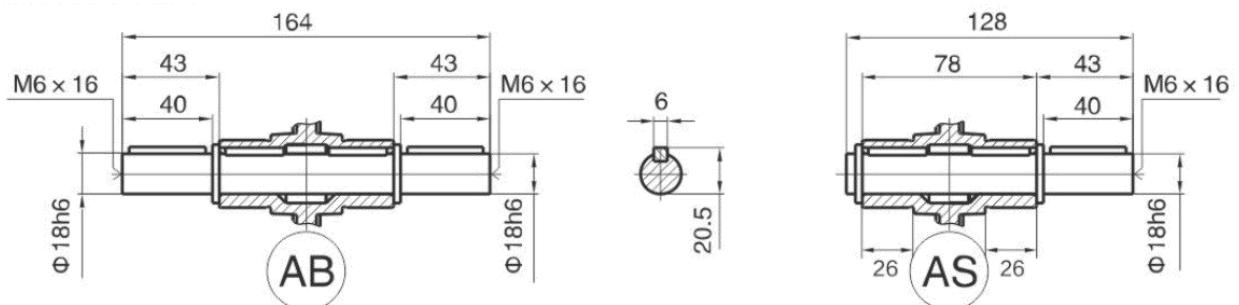

| Model | Gear Ratio | | | | | | | |
|---------------|--------------------------------------|-------------------|-------------------|-------------------|-------------------|-------------------|-------------------|-------------------|
| | 5 | 7.5 | 10 | 15 | 20 | 25 | 30 | 50 |
| NMRV50 | Moment Permissible Torque(Nm)[lb-in] | | | | | | | |
| | 73.00 [646.1] | 72.00 [637.25] | 70.00 [619.55] | 75.00 [663.81] | 70.00 [619.55] | 70.00 [619.55] | 85.00 [752.31] | 74.00 [654.96] |
| | Efficiency | | | | | | | |
| | 89% | 88% | 86% | 82% | 79% | 76% | 72% | 63% |
| | Shaft Maximum Radial Load(kN) | | | | | | | |
| | 1.57 | 1.80 | 1.98 | 2.27 | 2.5 | 2.69 | 2.86 | 3.39 |
| | Backlash@No-Load(°) | | | | | | | |
| | 1 | | | | | | | |

Dimension

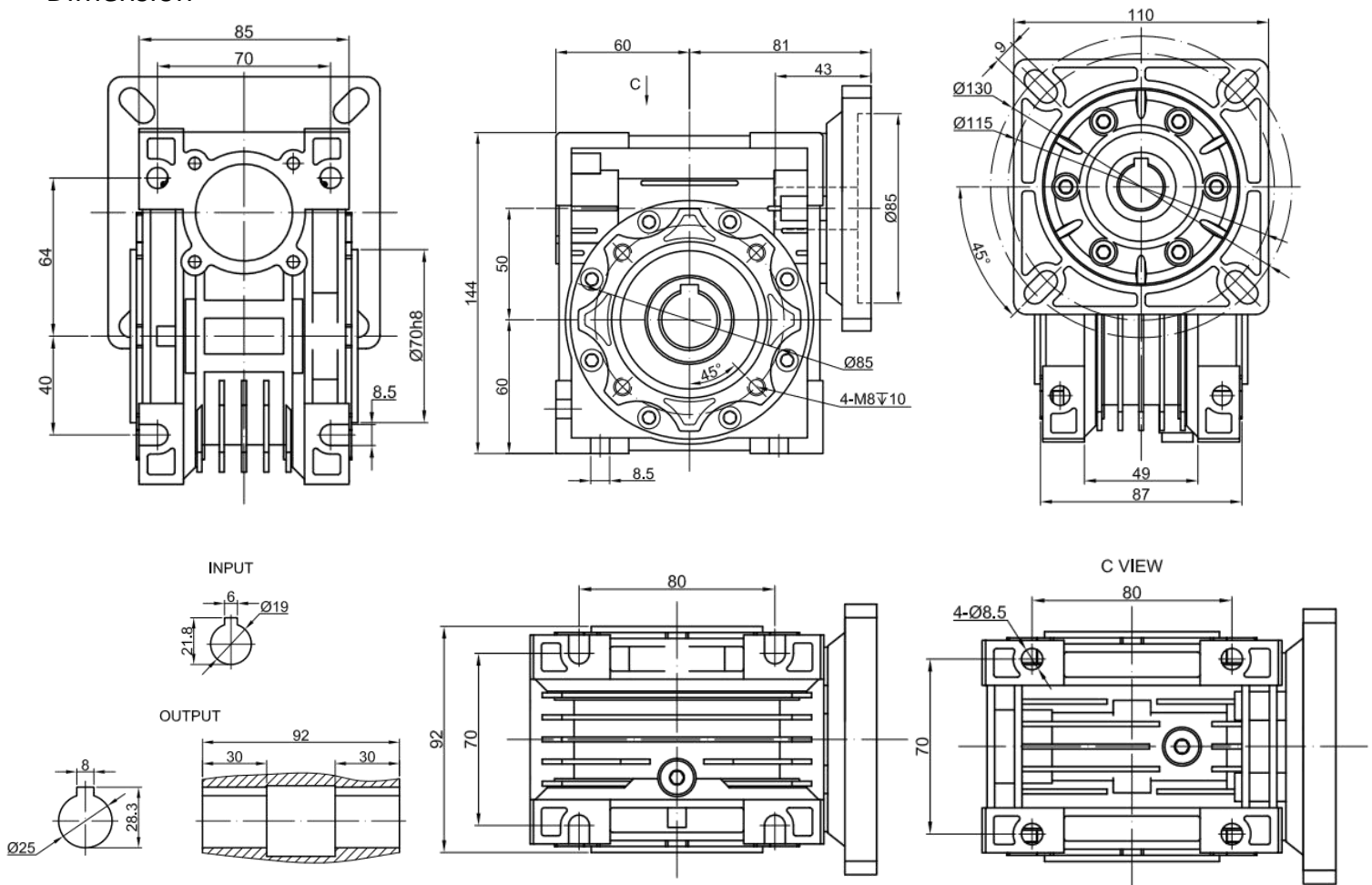

Output Shaft

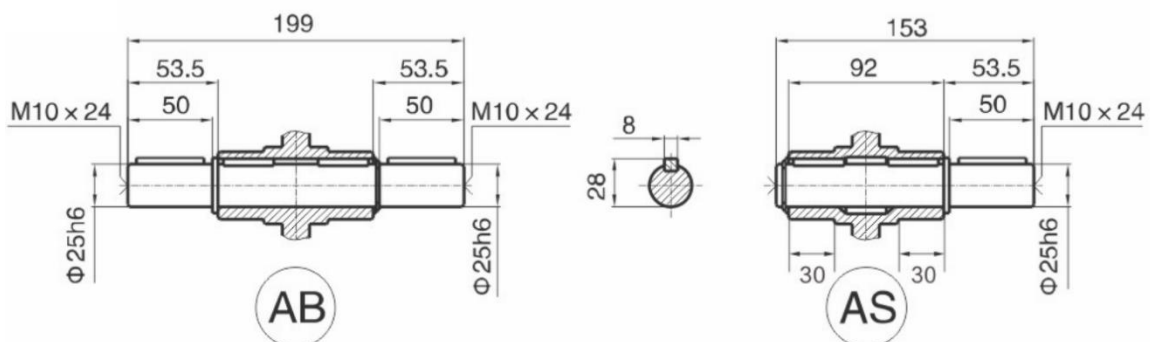

Position of output shaft

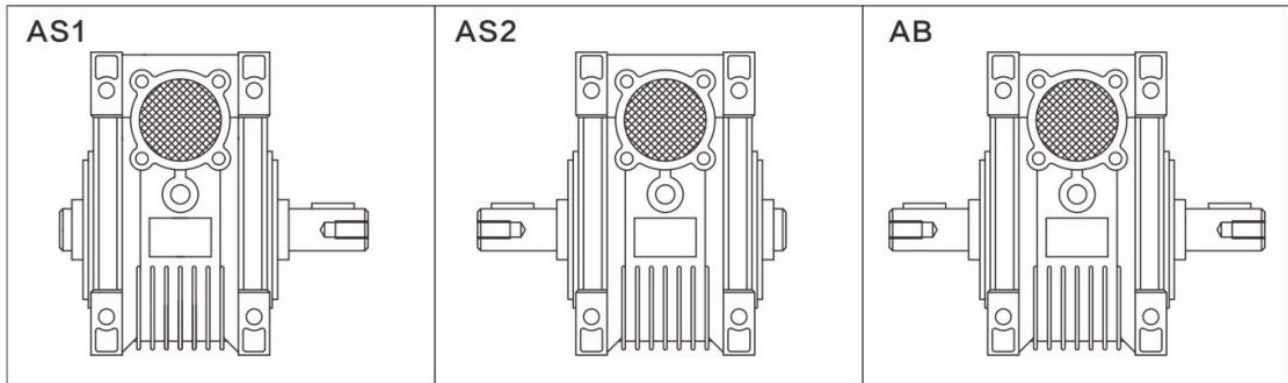

Operating Instructions

1 Single-stage worm gear reducer

- 1.1 It adopts high quality aluminum alloy die-casting box. It has a beautiful appearance, compact structure, small volume, light weight, saving installation space, and not easy to rust and corrosion.
- 1.2 Good heat dissipation performance, safe and reliable, high efficiency.
- 1.3 High load capacity, smooth transmission, low vibration and low noise.
- 1.4 A variety connecting structures with power input and torque output to meet the needs of a variety of connections; box exterior design and the setting layout of the foot hole can adapt to a variety of installation methods, with strong versatility.

2 Installation precautions

- 2.1 The reducer must be installed on a flat and solid base, the foot bolt must be tight and anti-vibration.
- 2.2 The coupling shaft extension of the prime mover-reducer-working machine must be accurately aligned with each other's axis after installation.
- 2.3 The outer diameter tolerance of the reducer input end and output end shaft extension is made according to h6, and the matching couplings, pulleys, sprockets and other transmission parts need to be configured according to the appropriate tolerance size. In order to avoid assembly too tight to damage the bearings, avoid assembly too loose to affect the normal power transmission.
- 2.4 When shaft extension is installed on sprockets, gears and other transmission parts, it should be as close to the bearing as possible to reduce the bending stress of shaft extension.

3 Precautions for use

- 3.1 Before use, attention should be paid to check whether the reducer type structure, center distance specification, transmission ratio, input shaft connection, output shaft structure, axis pointing of input shaft output shaft and rotation direction are in line with the use requirements, and the worm input speed should not exceed 1500r/min.
- 3.2 When starting the machine, the load should be applied gradually and not start at full load.
- 3.3 The reducer is equipped with oil filling hole and oil drain hole, ISOVg320 lubricating oil has been added in the reducer at the factory, users do not need to refuel again. After 500 hours of continuous operation, the lubricant oil should be changed. After that, the oil change cycle is 6000 hours.

3.4 The maximum allowable oil temperature of the reducer is 85°C, and it should be stopped for inspection when it exceeds.

3.5 If the reducer has been placed for more than 4-6 months before use, while the oil seal is not immersed in lubricating oil, it is recommended to replace the oil seal.

3.6 If the use environment temperature of the reducer is more than or less than the use environment temperature specified in the table by more than 5°C, please contact our company personnel.

Malfunctions Analysis

| Fault Description | Reasons | Solutions |
|---|--|---|
| Overheating | Improper connection among prime mover, reducer and the operation device | Adjust to proper position |
| | Overloading | Adjust to proper load |
| | Over Friction of oil seals | Drop lubricant at oil seal |
| | Lubricant oil over much or shortage | Adjust to proper oil quantity as lubricant capacity table |
| | Much impurity in oil or inferior oil | Refill proper oil |
| Vibration | Prime mover, reducer and the operation device mount badly | Find out the bad place, tighten it |
| | Tooth surface of worm gear sets worm-out or damaged | Replace worm gear sets(we will cooperate with you when necessary) |
| | Bearing worn-out | Replace Bearing |
| | Bolt loose | Tighten Screw |
| Noise | Improper connection among prime mover, reducer and the operation device | Adjust to proper position |
| | Bearing damaged or too large clearance | Replace Bearing |
| | Worm gear sets mesh badly | Mend tooth surface or replace worm gear sets(please contact to us) |
| | Lubricant oil shortage | Fill in adequate oil as lubricant capacity table |
| Oil leakage | Oil seal lip worm- out | Replace oil seal |
| | Shalt of oil seal area worn-out | Replace input or output shall with worm gear |
| | Oil screw plug loose | Tighten oil screw plug |
| | Oil gauge damaged | Replace oil gauge |
| Tooth surface of worm gear sets abrade extra- quickly | Overload | Adjust to proper loading |
| | Lubricant oil not according with requirement | Replace proper lubricant oil |
| | Lubricant oil shortage | Fill adequate oil as indication |
| | Not replacing lubricant oil in time according to requirement, oil deteriorates | Replacing oil in time according to requirement |
| | Overheating while running | 1. Deal with it as"Overheating" 2. Adopting proper measures to make environment temperature fall |

Annotate:

1. Accored after the lubricant changed.
2. If other faults not listed above occur, Please contact with us at any moment, Our company will supply thorough consultation and service.